

Apros[®] Nuclear - Success stories

Loviisa case 3: Modelling and Analysis of Loviisa HP-turbine and moisture separator reheater

Modelling and Analysis work to guarantee the plant's reliable and safe operation after installation work.

During the renewal project of Loviisa Nuclear power plant (NPP) high pressure steam turbine and moisture separator reheater (MSR) in 2013, the analysis model on Loviisa NPP was updated according to the new equipment data.

The purpose of the modelling and analysis work was to seek for potential problems in advance that could affect the plant operation and give time to design the corresponding corrective measures to achieve reliable and safe operation of the plant after the installation work.

The existing analysis model was updated to correspond the new HP-turbine and MSR-data. The modelling work also included some improvements to the related auxiliary systems such as condensate lines connected to MSR (e.g finer nodalisation for more precise simulation of flashing phenomena during transients). The analysis work consisted total of 12 transients cases with addition to 100% steady state condition. Since the

renewal project will be implemented in three phases starting in 2015, also three different simulation models were created to correspond the different stages of the installation work.

The analysis work proved to be successful and some corrective measures are under implementation to take into account e.g the changes in HP-turbine extraction pressures which will have an effect to the flow capacity of corresponding condensate systems.

Loviisa nuclear power plant, Finland

Loviisa nuclear power plant has two VVER pressurised water reactors, Loviisa 1 and Loviisa 2, with capacities of 498 MW net and 500 MW net. Loviisa 1 was commissioned in 1977 and Loviisa 2 in 1980. The operating licence for Loviisa 1 is valid until 2027 and Loviisa 2 until 2030.

In 2015 the production of the power plant totalled 8.47 TWh, i.e. about 13% of Finland's electricity production.

On an international scale, the 92.9% load factor of the Loviisa nuclear power plant was among the best in the world for pressurised water reactor power plants. Loviisa unit 1's load factor was 92.7% and Loviisa unit 2's 93.1%. Loviisa 1's production output was the fourth highest in the history of the plant.

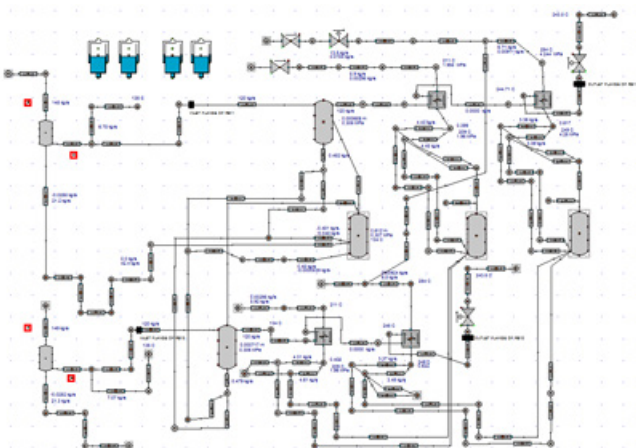
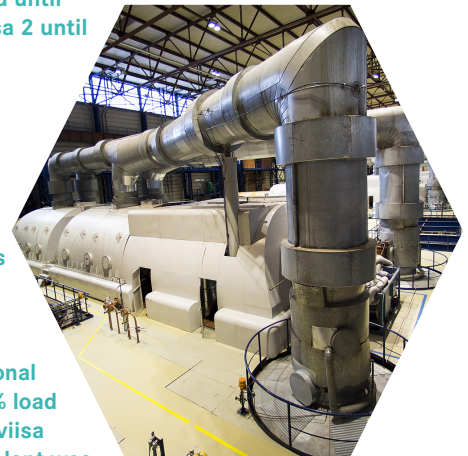

Fortum, Nuclear Services
P.O.Box 100, Tel. +358 10 45 411
www.fortum.com/powersolutions
www.apros.fi

For further information, please contact:
Kari Porkholm, Product Manager,
kari.porkholm@fortum.com, Tel. +358 50 453 2449
Matti Paljakka, Key Account Manager,
matti.paljakka@vtt.fi, Tel. +358 20 722 6423

In partnership with

